

Fitting Instructions



SKU

TXR849

PRODUCT

TAG 4x4 Recovery Towbar for Nissan Navara (Styleside 02/2021 - on)

SPECIFICATIONS

- Towbar Class: CL 4 Heavy Duty
- Towing Capacity: 3500kg
- Tow ball Weight: 350kg
- Approx. Fitment Time: 45 Minutes



Scan for latest version of these instructions

TOOLS REQUIRED

- Spanners
- Sockets
- Torque Wrench

IN THIS GUIDE

- Fitment Instructions
- Torque Settings
- Warranty Info

Towbar Assembly

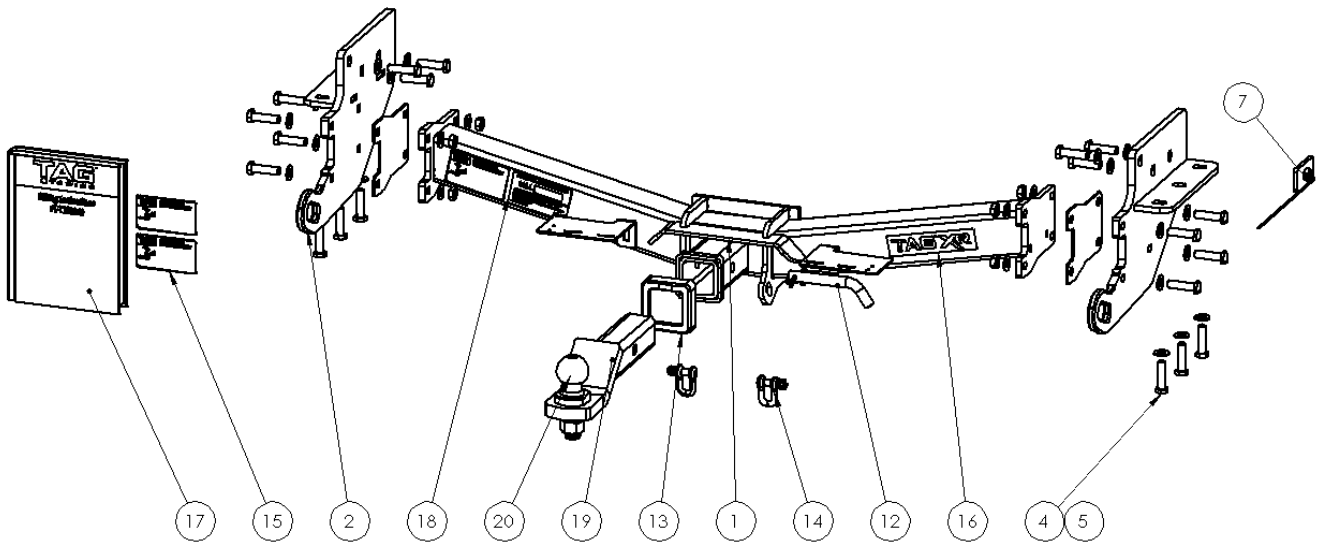

Item No.	Description	QTY.	Item No.	Description	QTY.
1	Main Bar Assembly	1	10	TAG Hitch Cover	1
2	End Plate Assembly	1	11	D-Shackle - 10mm. 1000kg	2
3	End Plate Assembly DS	1	12	TAG Compliance Sticker	3
4	M12 x 1.25 x 45 Hex Bolt	20	13	TAG XR Sticker 150 x 33mm	1
5	M12 Flat Washer	28	14	Fitting Instruction	1
6	Plate w/ wire & M12 x 1.25 nut	1	15	Tag WLL Sticker	1
7	M12 x 1.25 Nut	8	16	L4045 POWDER COATED TBM	1
8	End Plate Packer	2	17	50mm TAG Tow Ball – Zinc Plated	1
9	Class 4 Pin & Clip				

Important Information



Warning:

- This product is for towing purposes only and must only be loaded as shown in your vehicle Owner's Manual.
- This towbar is NOT to be drilled, cut, welded, or modified in any way.
- Check behind chassis rail and body panels before drilling to ensure no hazards are present.
- All load ratings shown are under the assumption your trailer has a functional braking system installed.
- When installed in positions other than the one depicted in these instructions the Tow Ball Mount may interfere or obstruct certain features of your vehicle (tailgate opening, Chassis clearance, etc.)

General:

- Before fitting this towbar read fitting instructions and check installation hardware is correct.
- Check that the towbar is suitable for the vehicle and be wary of any changes to the vehicle design that may conflict with the fitting of this towbar. (Tray, Canopy, Suspension etc.)
- After drilling, blow any filings clear, remove any burrs and treat exposed metal with a rust inhibitor.
- The high tensile fasteners supplied with this product are an integral feature to achieving the specified rating, if replacement is required ensure that fasteners of the same grade (8.8) & quality are used. Contact an authorised TAG distributor or the TAG fitment center - (07) 3208 3022 - if further information is required.

Towbar Maintenance and Care:

It is recommended, when not in use, that the Tow Ball Mount assembly and class 4 Pin and Clip is stored inside the car away from moisture to prevent standing water from forming rust. Inspect to ensure, on regular basis, fasteners are torqued to the specifications below and in good condition.

Ensure that the fitting instructions are read and understood prior to fitment, Following the fitment place these instructions in the vehicle's glovebox after installation is completed.

Metric Bolt Torque Settings

Diameter	Pitch	Grade	Torque	Unit		Diameter	Pitch	Grade	Torque	Unit
M8	1.25	8.8	29	Nm		M12	1.25	10.9	125	Nm
M10	1.25	8.8	57	Nm		M12	1.50	10.9	105	Nm
M10	1.50	8.8	44	Nm		M14	1.25	10.9	195	Nm
M12	1.25	8.8	101	Nm		M14	1.50	10.9	165	Nm
M12	1.50	8.8	97	Nm		M16	1.25	10.9	295	Nm
M12	1.75	8.8	77	Nm		M16	1.50	10.9	250	Nm
M14	2.00	8.8	122	Nm		50mm Tow Ball	N/A	N/A	300	Nm
M16	2.00	8.8	190	Nm		70mm Tow Ball	N/A	N/A	750	Nm

Installation Instructions



Step 1: Fit Towbar

- Remove & discard shipping hook and bolts from PS chassis.
- Loosely fasten the PS end plate assembly to the chassis with 3x M12x 45 bolts on the underside & 3 M12x 45 bolts on the inside face.
- Insert M12 nut plate into the DS chassis & align with the forward-most hole. Loosely fasten the DS end plate assembly to chassis with 3x M12x 45 bolts on the underside & 3 M12x 45 bolts on the inside face.
- Lift the main bar assembly up to the end plates and loosely fasten with the remaining Bolts, washers & nuts.
- Beginning at the chassis bolts, tighten all bolts according to the Torque Table (Pg 3).

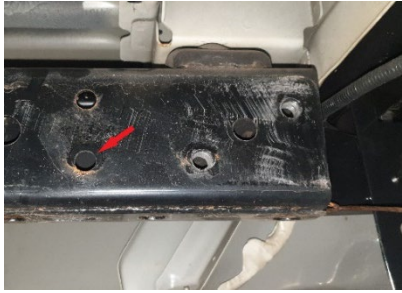

Step 2: Complete towbar & Apply Compliance Label

- Attach plastic hitch surround. Insert ball mount & secure with pull pin & clip
- Apply one of the compliance labels to the pillar of the driver's door. Leave the remaining label and the fitting instructions in the vehicle handbook.



TAG Warranty Statement



SWD warrants your TAG Towbar for its full product life under the following conditions:

- You can show proof of purchase.
- The towbar has been correctly installed by a suitably qualified installer.
- The towbar has not been modified or abused in any way and has only been used for the purpose intended.
- The towbar was not fitted second hand to your vehicle.

The extent of this warranty includes materials and workmanship used in the manufacture of the towbar and is to the equivalent value of current, full replacement cost.

Nothing stated or implied in this warranty limits in any way, the statutory rights that you may have.

To make a claim visit the original installer in the first instance or, if you are unable to or are not satisfied with their help, then contact us direct by phone on 1300 669122 or visit www.swd.com.au.