

TOP VIEW

CAPACITY = 30 LITRES  
 DRY WEIGHT = 4.05 kg  
 MATERIAL = POLYETHYLENE  
 COLOUR = BLACK  
 WALL THICKNESS = 6mm Min.

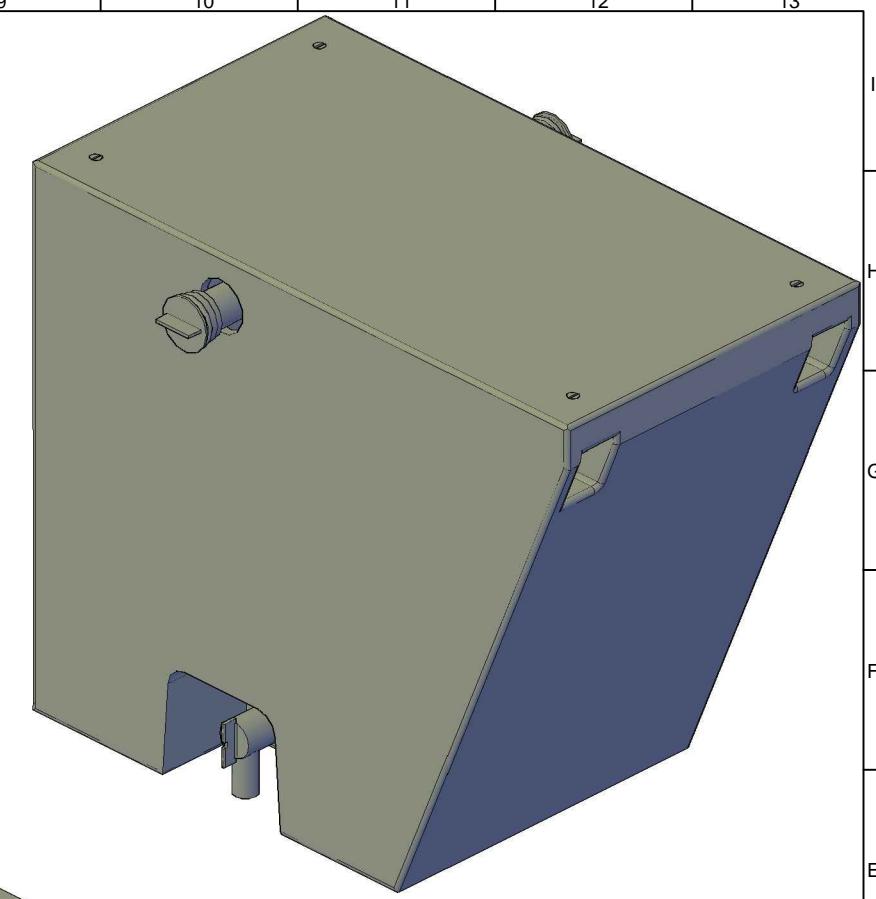

ISOMETRIC VIEW

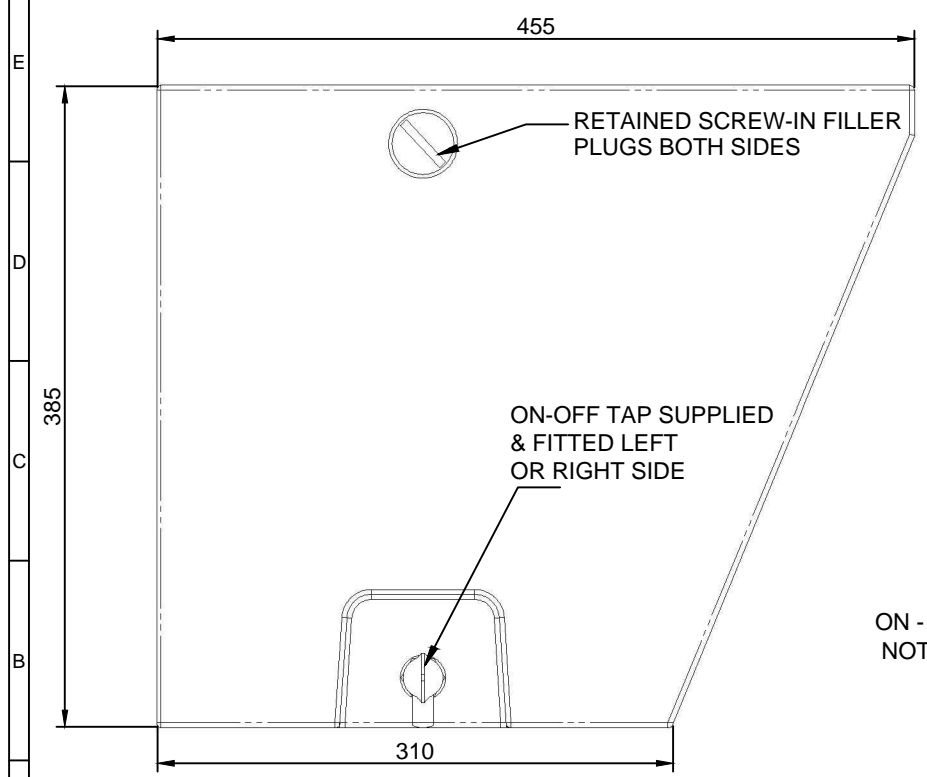

FRONT VIEW

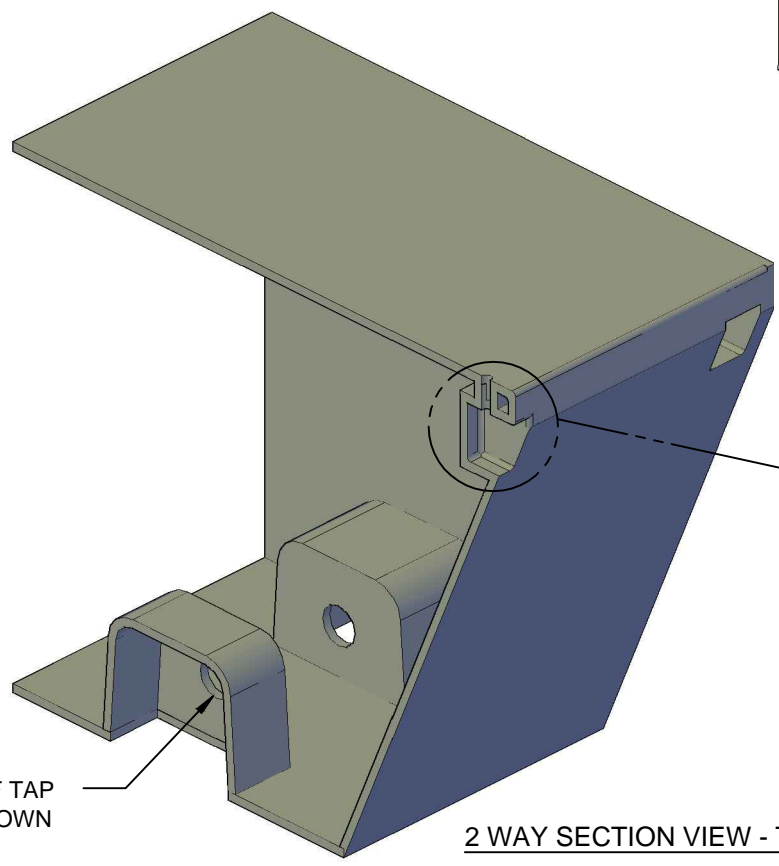

2 WAY SECTION VIEW - TANK BODY

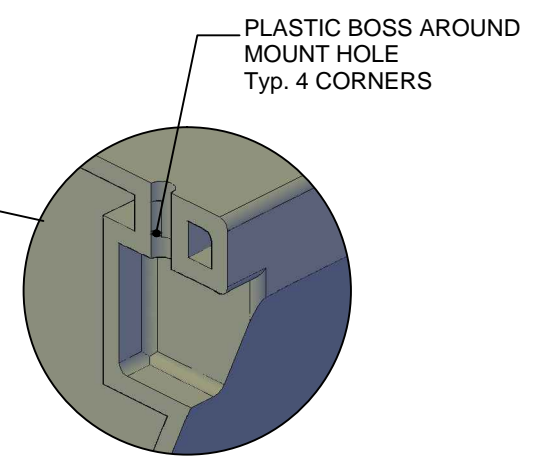

DETAIL A  
SCALE 1:2

REV.	DESCRIPTION	DATE	APPROVED
1	REVISIONS		
2			
3			
4			
5			
6			

References:-		Client: TOOWOOMBA PLASTICS & SHEETMETAL	
COPYRIGHT AND REPRODUCTION		Project:	
Copyright in the drawings information and data recorded hereon and their format and presentation ("data") is the property of 3D CADWORKS and may not be used, copied or reproduced in whole or part for any purpose other than that for which it is supplied by 3D CADWORKS without the prior consent of 3D CADWORKS. 3D CADWORKS is not responsible for any document or part of a document produced containing data unless that document or the relevant part is identical to the document provided herewith ("the accompanying document"). The terms printed on this label are part of a data and the accompanying documents and must be contained of affixed to any reproduction of the data or the accompanying documents.		Title: 30 Ltr UNDER TRAY TANK - LEFT or RIGHT GENERAL ARRANGEMENT	
Sheet Size <b>A3</b>	Date: 11-05-05	3D Cadworks E-MAIL- bruce@3dcadworks.com	
AS 1100-1993	Scale: 1:4	8 Daranlee Court PHONE (07) 4638 0281 Toowoomba Qld 4350 Fax (07) 4638 0281	
THIRD ANGLE PROJECTION	Drawn By: B Fowler	Drawing No. 05015-001-S1-01-CPT-	
Cad File:	Designed By: TP&S	Rev. -+	
	Checked By: -		